

VAG CEREX 300-W BANA WAFER

PN 10/16 - DN 50...600

KAT-A 1331-W-Gu-Wafer



- μ μ μ 593
- μ μ μ 558-1, 20(DIN 3202/K1)
- Wafer μ μ μ 1092-2
- μ μ μ
- μ μ μ μ V
- μ μ μ
- 1 Torr
- μ μ μ μ ISO 5211

- μ : EN-JS 1030(GGG40)
- : EN-JS 1030(GGG40)
- : 1.4021
- :EPDM

- μ :
- :

- μ
- μ
- μ μ
- μ

- μ μ 5 bar μ

- μ μ μ
- 12266 (DIN 3230 μ 4)
- μ μ μ DVGW
- μ μ μ W270
- μ TA-Luft

- μ
- 16: 4m/s
- PN 10: 3m/s

_ 1331

DN	PN	[bar]	[°C]
50...600	16	16	50
200...600	10	10	50

PN 16 - DN 450...600

μ μ μ	μ μ μ
[bar]	[bar]
24	18
15	11

12266

VAG CEREX 300-W BANA WAFER

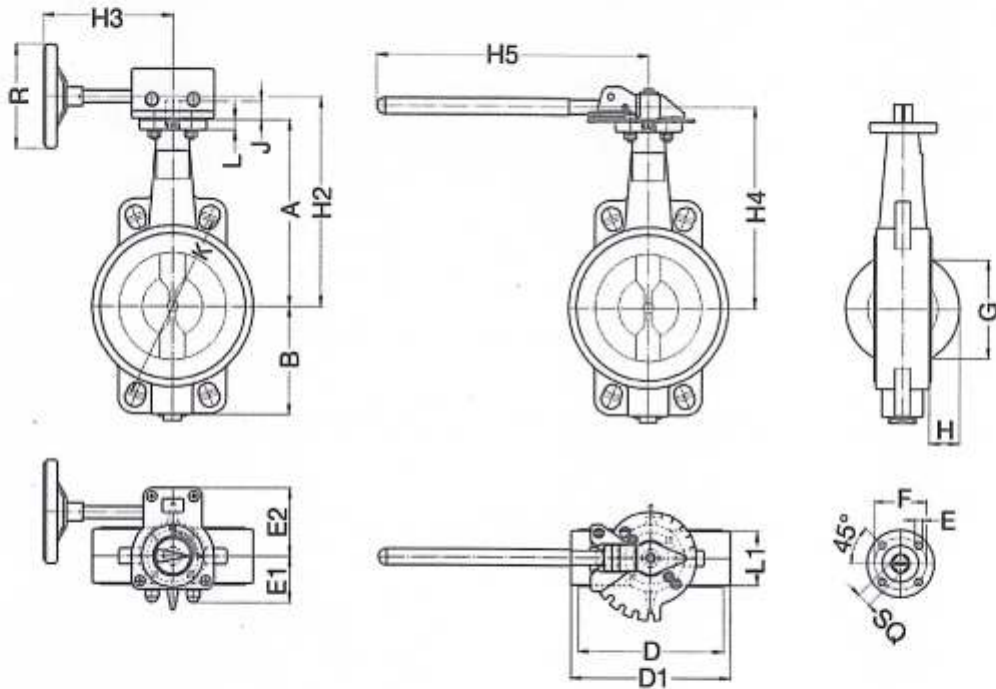

PN 16

DN		50	65	80	100	125	150	200	250	300	350	400	450
A	[mm]	125	132	140	180	190	220	240	275	300	320	380	400
B	[mm]	72	80	87	113	123	155	175	205	230	270	315	327
D	[mm]	87	102	112	142	161	201	252	301	356	400	450	500
D1	[mm]	98	114	132	156	185	216	286	323	377	435	485	546
E	[mm]	7	7	7	7	7	10	10	12	12	14	18	18
E1	[mm]	48	48	48	48	48	48	56	56	79	79	83	110
E2	[mm]	66	66	66	66	66	66	75	75	95	95	126	148
F	[mm]	50	50	50	50	50	70	70	102	102	125	140	140
G	[mm]	31	51	69	91	115	149	188	239	288	329	383	412
H	[mm]	5	12	19	27	37	52	70	91	111	126	149	158
H2	[mm]	155	160	170	210	220	250	270	305	340	360	420	450
H3	[mm]	120	120	120	120	120	180	195	195	295	295	380	350
H4	[mm]	140	146	155	195	205	238	258	-	-	-	-	-
H5	[mm]	225	225	225	225	225	305	305	-	-	-	-	-
ISO		F05	F05	F05	F05	F05	F07	F07	F10	F10	F12	F14	F14
J	[mm]	12	12	12	16	16	19	19	24	24	24	29	38
K	[mm]	125	145	160	180	210	240	295	355	410	470	525	585
L	[mm]	10	10	10	10	10	12	12	14	14	18	21	21
L1	[mm]	43	46	46	52	56	56	60	68	78	92	102	114
R	[mm]	125	125	125	125	125	200	200	200	300	300	400	500
SQ	[mm]	11	11	11	14	14	17	17	22	22	22	27	36
μ		4	4	4	4	4	4	4	4	4	4	4	4
kg		2.5	3.1	4	5.1	7	8.9	18.5	22.3	34.8	43	62	90
μ kg		3.2	3.8	4.6	5.8	7.6	9.9	19.5	-	-	-	-	-
μ μ kg		3.8	4.4	5.3	6.4	8.3	10.3	20.4	24.2	37.7	48.0	68.0	112.0

PN 16

DN		500	600
A	[mm]	460	500
B	[mm]	365	435
D	[mm]	550	645
D1	[mm]	606	720
E	[mm]	22	22
E1	[mm]	110	143
E2	[mm]	148	260
F	[mm]	165	165
G	[mm]	470	560
H	[mm]	181	214
H2	[mm]	510	555
H3	[mm]	350	390
ISO		F16	F16
J	[mm]	38	48
K	[mm]	650	770
L	[mm]	24	24
L1	[mm]	127	154
R	[mm]	500	700
SQ	[mm]	36	46
	kg	4	4
	μ kg	125	185
	μ μ kg	147.0	230.0

PN 10

DN		200	250	300	350	400	450	500	600
A	[mm]	240	275	300	320	380	400	460	500
B	[mm]	175	205	230	270	315	327	365	435
D	[mm]	252	301	356	400	450	500	550	645
D1	[mm]	286	323	377	430	480	530	582	682
E	[mm]	10	12	12	14	18	18	22	22
E1	[mm]	56	56	79	79	83	110	110	143
E2	[mm]	75	75	95	95	126	148	148	260
F	[mm]	70	102	102	125	140	140	165	165
G	[mm]	188	239	288	329	383	412	470	560
H	[mm]	70	91	111	126	149	158	181	214
H2	[mm]	270	305	340	360	420	450	510	555
H3	[mm]	195	195	295	295	380	350	350	390
H4	[mm]	262	-	-	-	-	-	-	-
H5	[mm]	300	-	-	-	-	-	-	-
ISO		F07	F10	F10	F12	F14	F14	F16	F16
J	[mm]	19	24	24	24	29	38	38	48
K	[mm]	295	350	400	460	515	565	620	725
L	[mm]	12	14	14	18	21	21	24	24
L1	[mm]	60	68	78	92	102	114	127	154
R	[mm]	200	200	300	300	400	500	500	700
SQ	[mm]	17	22	22	22	27	36	36	46
	μ	4	4	4	4	4	4	-	-
	kg	-	-	-	-	-	-	4	4
	kg	18.5	22.3	34.8	43	62	90	125	185
	μ kg	19.5	-	-	-	-	-	-	-
	μ μ kg	20.4	24.2	37.7	48.0	68.0	112.0	147.0	230.0